

APPLICATION:

JOB NAME:

QUANTITY:                      ITEM NO.

PRODUCT NAME:

TROUGH INLET FITTING - 1/2" INLET

SPECIAL CONFIGURATION  
CHECK BASE MODEL AND OPTIONS

MODEL:

2905

OPTIONS OR MODIFICATIONS:

OTHER \_\_\_\_\_

**FEATURES**

- \* 1/2" MALE NPT INLET
- \* SLIP JOINT KIT INCLUDED

**SYSTEM LIMITS**

- \* TEMP: 40°F MIN. TO 140°F MAX.
- \* PRESSURE: 200 PSI MAX. STATIC
- \* 5.0 GPM AT 80 PSI

**SHIPPING WEIGHT**

- \* 0.5 LBS

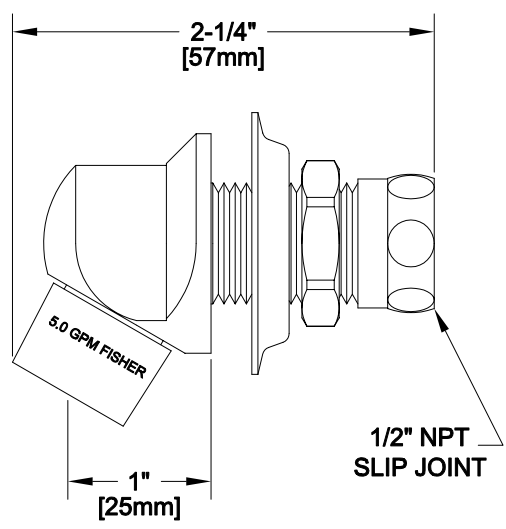
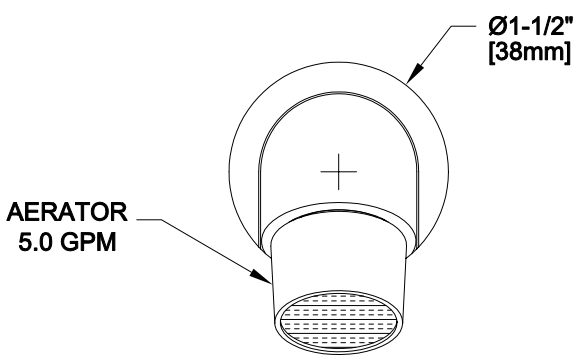

**ROUGH-IN:**

